



EHI-SW with LCD display

EHI-SW with LED display

Features

- **Applications:** Industrial and commercial weighing
- **Resolution:** 100 -100,000d primary units; 100 - 125,000d secondary units
- **Construction:** IP65 stainless steel enclosure to withstand harsh treatment and corrosive environment
With swivel bracket suitable to use on table, column or wall
- **Display:** LCD version: 6 digits 7-segments 1" (25mm) high FSTN LCD display with blue backlight
LED version: 7 digits 7-segments 0.7" (17mm) high ultra bright red LED display
- **Keys:** ZERO/ON/OFF, TARE/PRESET, UNIT/DATA, N/G/TOTAL, PRINT/FUNC, HOLD/SETUP
- **Functions:** Weighing, Counting, Check Weighing, Percentage Weighing
Net and Gross display, Auto-off time setting;
Programmable hold function with peak and average capabilities
Fine tune weight adjustment
Remote digital input, Digital output, Analog voltage output

Specifications

Item	Parameters
Loadcell Capability	8 @ 350ohm
Excitation voltage	5V DC
Wiring	4 wires or 6 wires
Units of Measure	kg, lb, lb:oz, g, oz, pcs, %
Interfaces	RS232, RS485, optional Bluetooth
Power	12V 500mA adapter and 6V 4Ah lead-acid rechargeable battery
Operation Temp	-10°C to 40°C (14°F to 104°F)
Packing size	580x305x354cm/4pcs/ctn G.W.: 14kg N.W.: 12kg
Approvals	CE and WEEE directive, UL/CE/BS approved power adapter
Options	RS232 cable, RS485 cable

Dimensions (mm/inch)

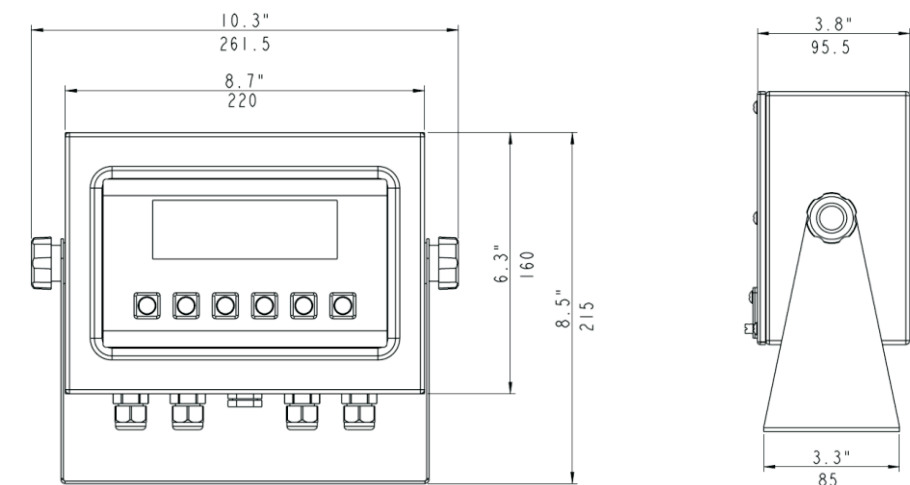

- Washdown full stainless steel enclosure, waterproof rate to IP65



- Powered by: 6V 4Ah lead-acid rechargeable battery or built-in AC adapter



- Bi-directional RS232 interface and half RS485, allows to communicate with computer or other devices